

Property at 00127 MONTEVIDEO ROAD

Prop ID 3180127

Printed 15-Oct-2011 10:30 PM Design and Layout (C) Right/Angles

**Administrative Information**  
 Owner name: COHEN JEROME S TRUSTEE  
 Second name: MONTEVIDEO RD QUAL PERS TRST  
 Address: 16487 NE 27TH PLACE  
 City/state: NORTH MIAMI BEACH FL Zip: 33160

**Building Valuation Summary**

Dwelling	Frame	2 story w/bsmt	Area	1,924	312,510
Basement	Full				
Heating	Yes	A/C Yes			9,470
Plumbing	4 F/B	2 H/B	4 Add'l fix.	1 Wh/p	Saunas 20,100
Attic	None		Attic size:		
Additions					186,300
Other Features	WB Stks		Unfin	3,500	35,400
<b>Sub-Total</b>					<b>563,780</b>
Grade	A+	Factor	1.6700		941,510
CDU		C&D Factor	1.00		941,510
Depreciation			20 %		753,210
Computed cost value @ 70%					527,250

<b>Location Information</b>			
Map: 009	Clerk map:		
Lot: 3180127	Neigh.:	Zone: RU2A	Vol: 626 Page: 955
<b>Assessments</b>		<b>Exemptions</b>	
Assmt category	Qty	Amount	Exempt Cat
Resident Land	2.00	105,000	
Resident Dwelling	1.00	527,250	
Resident Excess	4.70	24,680	
<b>Summary</b>		<b>Utilities</b>	
Total assessments	656,930	Water	Well
Total exemptions		Sewer	Septic
Net assessment	656,930	Gas	None
		<b>Values</b>	
		Sale date: 29-Sep-1983	
		Sale price: 150,000	
		Sale valid:	
		Mkt value :	
		Cost value: 938,470	
		<b>Sales ratios</b>	
		Cost/sale : 6.2565	
		Mkt/sale :	
		Assmt/sale: 4.3795	

**Building additions**

Category	Type	Area	Value
P Porches, Patios, Decks	DECK Wood deck	253	4,700
L Living Area	OVER Frame Overhang	16	1,000
P Porches, Patios, Decks	DECK Wood deck	198	3,700
P Porches, Patios, Decks	FOFF Frame open first flo	198	8,500
L Living Area	FRFF Frame first floor	240	19,400
L Living Area	FRUF Frame upper full	240	14,200
L Living Area	FRUF Frame upper full	240	14,200
L Living Area	FRFF Frame first floor	28	2,300
L Living Area	FRUF Frame upper full	28	1,700
P Porches, Patios, Decks	DECK Wood deck	352	6,600
L Living Area	OVER Frame Overhang	44	2,800
L Living Area	FRFF Frame first floor	58	4,700
P Porches, Patios, Decks	FOFF Frame open first flo	24	1,000
L Living Area	FRFF Frame first floor	294	23,700
L Living Area	FATT Full finished attic	200	5,100
G Garages	FR Attached frame LE 65	576	18,400
L Living Area	FRUH Frame upper half	576	20,800
P Porches, Patios, Decks	DECK Wood deck	515	9,600
P Porches, Patios, Decks	FOFF Frame open first flo	515	22,100
P Porches, Patios, Decks	DECK Wood deck	98	1,800
<b>Total additions</b>			<b>186,300</b>

**Land Information**

Type	Use	Acres/SqFt	Rate	Total	Infl Fact	Value	70% Value
PRIM	11	2,000	300,000		TO .50	150,000	105,000
Primary Site				Topography			
RES	12	4,700	7,500			35,250	24,680
Residual		204,732					
6.7000 acres				Total land value		185,250	129,680

**Residential Dwelling Information**

Subject	Code	Description	Condominium	
Style	06	Contemporary		
Exterior Walls	05	Stucco		
Roof Material	01	Asphalt Shingles	Story Height 2.0	
Roof Type	01	Gable		
Foundation	01	Poured Concrete	Total Rooms	9
Interior Walls	02	Drywall	Garage cars	2
Floors	07	Hardwood/Carpeti	Bedrooms	5
Heating System	02	Forced Hot Air	Unfinished area	
Fuel	01	Oil	Family Rooms	1
Attic	99	None	Dormer linear f	
Grade	53	A+	Full Baths	4
Garage	22	Attached 2 car	Masonry trim sf	
Area Over Gar.	03	Partial	Half Baths	2
Basement	01	Full	Finish bsmt sz	1,200
Bsmt Fin Qual	04	Living Area w/o	Addtn'l fixtures	4
Air Condition	01	Central Air	Rec Room Size	
Interior Cond	05	Good	Whirlpools	1
Exterior Cond	05	Good	Saunas	1
			Living area	5,542
			# Living Units	
			M/F stacks	
			W/B stacks	2
			W/B openings	3
Actual Year Built: 1985				

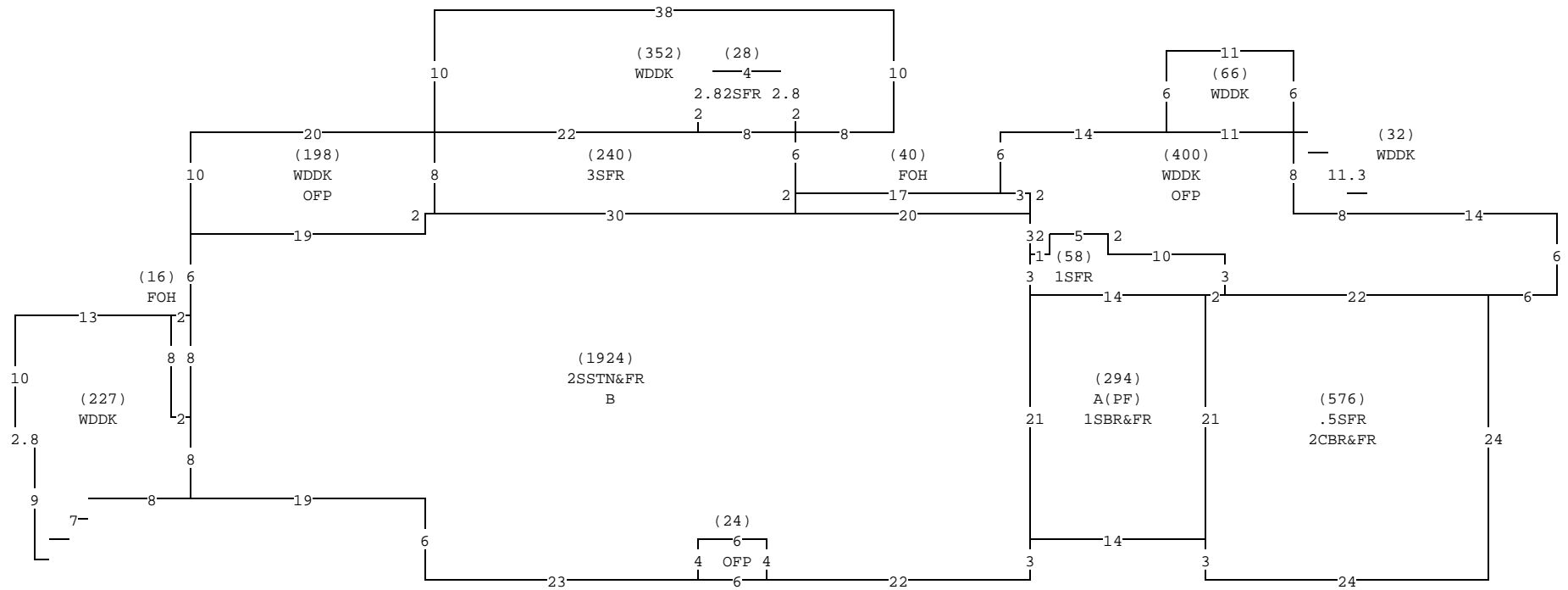

Notes: THE MONTEVIDEO ROAD QUALIFIED PERSONAL RESIDENCE TRUST 626/955 7-21-11